

**INTERLOCAL AGREEMENT BETWEEN HARRIS COUNTY AND HARRIS-WALLER
COUNTY MUNICIPAL UTILITY DISTRICT NO. 4**

This Interlocal Agreement (“Agreement”) is made and entered into by and between **Harris County** (“County”), a body corporate and politic under the laws of the State of Texas acting by and through its governing body the Harris County Commissioners Court, and **Harris-Waller County Municipal Utility District No. 4** (“District”) pursuant to the Interlocal Cooperation Act, Tex. Gov’t Code Ann. §§791.001 – 791.030. The County and District may each be referred to herein collectively as the “Parties” and individually as a “Party.”

1) GENERAL SCOPE OF SERVICES

- A) The District desires to construct non-standard elements such as brick pavers, upgraded street signs, upgraded crosswalks and intersections, recreational improvements, enhanced landscaping, enhanced lighting improvements, upgraded traffic signals, and related appurtenances (“Non-Standard Elements”), within the existing right-of-way in the Sunterra Subdivision (“Road ROW”) located in Harris County Precinct 4 as generally illustrated on Exhibit A attached hereto and incorporated herein by reference.
- B) The District agrees that the maintenance and repair of the Non-Standard Elements (“Maintenance”) is not standard maintenance for the County.
- C) The District warrants and represents it will perform the Maintenance in compliance with all federal, state, and local laws, ordinances, rules, and regulations relating to the Maintenance.
- D) Unless otherwise stated in this Agreement, words which have well-known technical or industry meanings are used in accordance with such recognized meaning.
- E) District shall verify that each subcontractor it retains to perform the Maintenance pursuant to this Agreement are in compliance with Section C above.
- F) District agrees that no part or appurtenance of the Road ROW shall be considered private property and the general public shall have the same access to such parts and appurtenances as to other County road right-of-ways.
- G) The Parties agree that a public purpose will be served by the Maintenance performed by the District in accordance with this Agreement and all funds expended for the performance of such Maintenance will be from current fiscal funds.

2) DISTRICT’S RESPONSIBILITIES

- A) District agrees to accept full ownership of the Non-Standard Elements and responsibility for the perpetual Maintenance of the Non-Standard Elements, at no cost to the County, in accordance with the standards set forth in this Agreement. District will, at no cost to the County, provide Maintenance of the Road ROW to the extent that the need for such Maintenance is a direct result of damage to the Non-Standard Elements or is otherwise directly caused by the Non-Standard Elements. The District shall have no responsibility for maintenance and repair of the Road ROW, except as stated in this Agreement.
- B) Maintenance required by the District shall include, but not be limited to, maintaining the intended function and the aesthetic appearance of the Non-Standard Elements. It shall also include removing and relocating the Non-Standard Elements if the County determines that

it will be desirable due to changes in applicable regulations, including the Texas Accessibility Standards, or planned future improvements to the intersections, such as signalization or construction of additional lanes. In addition to satisfying the standards set forth in this Agreement in performance of its maintenance responsibilities, the District's performance shall conform to the standards prevailing in the County at the time of such maintenance with respect to scope, quality, due diligence, and care, in regard to usual and customary maintenance by the County on its typical medians and appurtenances in the median.

- C) If the Harris County Engineer ("County Engineer") determines that any Maintenance work is not being performed in accordance with the standards for same, as specified in this Section, he/she may request that the work be discontinued. The District shall thereafter discontinue such work until the District demonstrates to the County Engineer that the work will be performed in accordance with such standards and the County Engineer provides notice that the District may proceed.
- D) District agrees to make necessary repairs to the Non-Standard Elements or medians, or the Road ROW to the extent such repairs to the Road ROW are necessary due to damage to the Non-Standard Elements or is otherwise caused by the Non-Standard Elements or Maintenance of the Non-Standard Elements, as soon as reasonably practicable. Should the deficiencies requiring such repairs endanger the public, the District shall implement interim safety measures until it can provide such Maintenance. However, the County may provide such measures on behalf of the District without prior notice to the District if the County Engineer, in his sole discretion, determines that it is necessary to implement interim safety measures until such time as the District can provide its own safety measures. The District shall be responsible for the cost incurred by the County in providing any interim safety measures on its behalf. In any event, the District agrees to provide necessary Maintenance within one hundred and twenty (120) days from the date the District becomes aware or reasonably should have become aware of the need for such Maintenance.
- E) Prevention and Repair of Damage. In performing the Maintenance, the District shall follow necessary safety measures and shall take measures to prevent damage to persons and property resulting from the conditions that the District is responsible for repairing and maintaining and resulting from repairs thereto.
- F) Notice of Repair or Maintenance. The District shall notify the County in writing before commencement of repair or maintenance work under this Section, other than routine maintenance. If the repair or maintenance is of an emergency nature, such notification may be provided by telephone and confirmed in writing as soon as reasonably practicable thereafter. The District shall provide written documentation to the County of the work done after completion of any non-routine maintenance or repairs within thirty (30) days of completion of such repairs.
- G) Failure to Maintain
 - a. If the County believes the District has failed to perform its Maintenance duties pursuant to this Agreement, the County shall notify the District in writing of such failure and allow the District sixty (60) days to cure any such failure ("Notice to Cure"). If the District has not taken reasonable steps to cure such failure within sixty (60) days of receipt of the Notice to Cure, then the County may, in its sole discretion, (a) alter, reduce, replace, remove, or authorize other changes to the Non-Standard

Elements, at the District's sole expense, including an administrative cost equal to 10% of the cost, or (b) terminate this Agreement.

- b. Notwithstanding the foregoing provisions in Section G(a), the County may perform such Maintenance if (a) the Non-Standard Elements are in need of Maintenance and (b) the District has failed to perform such Maintenance in a timely manner. If the County performs any Maintenance or removal of any of the Non-Standard Elements, the County shall not be required to restore the Non-Standard Elements to their previous condition or specifications. The District shall then have the right, at any time in the future, to enhance, replace, or restore any Non-Standard Elements repaired, replaced, modified, or removed by the County, and in this event, the District will return all salvageable materials utilized by the County.

3) COUNTY'S RESPONSIBILITIES

- A) The execution of this Agreement in itself does not constitute the County's approval of the Non-Standard Elements within the Road ROW. If drawings and specifications that include the Non-Standard Elements are submitted to the County in accordance with the Regulations of Harris County, Texas for the Approval and Acceptance of Infrastructure ("Regulations"), the County will review such drawings and specifications. If such drawings and specifications are approved by the County, the Non-Standard Elements must be constructed in accordance with the approved and permitted drawings and specifications.
- B) When the drawings and specifications are submitted to the County for permitting, the specific locations of any proposed Non-Standard Elements shall be clearly indicated on such drawings.
- C) In consideration of the District entering into this Agreement, the County agrees that it shall not refuse to approve the installation of the Non-Standard Elements if installed in accordance with the approved and permitted drawings.
- D) It is specifically agreed that the County shall have no responsibility for the condition or maintenance of the Non-Standard Elements.
- E) Notwithstanding any provision of this Agreement that might be construed to the contrary, the Non-Standard Elements shall be considered part of the Road ROW. The County may at any time alter or remove the Non-Standard Elements, at the District's sole expense, including an administrative cost equal to 10% of the cost, if and when the County, in the sole discretion of the County Engineer or the Applicable County Precinct Road and Bridge Superintendent ("County Representative"), determines it interferes with the proper use, safety, or operation of the Road Right-of-Way, for road purposes, or is necessary in order to make improvements to the Road, or has determined that the aesthetic appeal of the Non-Standard Elements has not been maintained. The County Engineer or the County Representative shall provide notice to the District at least sixty (60) days prior to any such alteration or removal. The County agrees that the District may replace, repair, or reconstruct the Non-Standard Elements altered or removed by the County pursuant to this Section 3(E), at the District's sole cost and expense and subject to approval of plans and specifications by the County. Otherwise, upon complete removal of the Non-Standard Elements, the District's maintenance responsibility shall end for the Non-Standard Elements.

4) INDEPENDENT PARTIES

This Agreement is not intended to create and shall not constitute a partnership or joint venture between the Parties. Each Party shall have and retain the exclusive right of control over employment, firing, discipline, compensation, insurance, and benefits in accordance with the applicable laws of the State of Texas. Neither Party has authority to bind or otherwise obligate the other Party orally, in writing or by any act or omission. Nothing contained herein shall establish an agency, employee-employer relationship, partnership, joint enterprise, joint employer, or joint venture relationship by or between the County and the District.

5) TERM

This Agreement is effective as of the date that it has been approved and executed by all Parties (the “Effective Date”) and remains in force and effect for a period of 20 years (“Term”). Thereafter, this Agreement shall be renewed for successive one (1) year terms (each a “Renewal Term”).

6) LIMITATION OF APPROPRIATION

The District understands and agrees, said understanding and agreement also being the absolute essence of this Agreement, that the County is not appropriating any funds under this Agreement.

7) TEXAS PUBLIC INFORMATION ACT

- A) The Parties expressly acknowledge that this Agreement is subject to the Texas Public Information Act, Tex. Gov’t Code Ann. §§ 552.001 *et seq.*, as amended (the “Act”). District expressly understands and agrees that the County shall release any and all information necessary to comply with Texas law without the prior written consent of District.
- B) It is expressly understood and agreed that the County, its officers and employees may request advice, decisions and opinions of the Attorney General of Texas (“Attorney General”) in regard to the application of the Act to any software, or any part thereof, or other information or data furnished to the County, whether or not the same are available to the public. It is further understood that the County, its officers and employees shall have the right to rely on the advice, decisions, and opinions of the Attorney General, and that the County, its officers, and employees shall have no liability or obligations to District for the disclosure to the public, or to any person or persons, of any software, or a part thereof, or other information or data furnished to the County in reliance on any advice, decision or opinion of the Attorney General.
- C) In the event the County receives a written request for information pursuant to the Act that affects District’s rights, title to, or interest in any information or data or a part thereof, furnished to the County by District under this Agreement, then the County will promptly notify District of such request. District may, at its own option and expense, prepare comments and submit information directly to the Attorney General stating why the requested information is exempt from disclosure pursuant to the requirements of the Act. District is solely responsible for submitting the memorandum brief and information to the Attorney General within the time period prescribed by the Act. District is solely responsible for seeking any declaratory or injunctive relief regarding the disclosure of information that it deems confidential or privileged.

- D) Electronic Mail Addresses. District affirmatively consents to the disclosure of its e-mail addresses that are provided to the County, including any agency or department of the County. This consent is intended to comply with the requirements of the Act, and shall survive termination of this Agreement. This consent shall apply to e-mail addresses provided by District and agents acting on behalf of District and shall apply to any e-mail address provided in any form for any reason whether related to this Agreement or otherwise.

8) TERMINATION

- A) This Agreement may be terminated by mutual written agreement and consent of the District and the County.
- B) If the County permanently removes Road Right-of-Way with Non-Standard Elements from the Road Log for any reason, the District will have no further Maintenance responsibility for the Non-Standard Elements or median under this Agreement. If the Road ROW with Non-Standard Elements covered under this Agreement are removed from the Road Log, this Agreement will terminate.
- C) The above termination provisions of this Section are in addition to rights of the County to terminate this Agreement under Section 2.
- D) *Force Majeure*. In the event that either Party is unable to perform any of its obligations under the Agreement or to enjoy any of the benefits because of natural disaster, actions or decrees of governmental bodies or communications line failure not the fault of the affected party (referred to as a “*Force Majeure* Event”), the Party who has been so affected immediately agrees to give notice to the other Party and agrees to do everything possible to resume performance. Upon receipt of such notice, the Agreement is immediately suspended. If the period of nonperformance exceeds ten (10) calendar days from the receipt of notice of the *Force Majeure* Event, the Party whose ability to perform has not been so affected may terminate the Agreement immediately by giving written notice to the other Party.
- E) Copies of all completed or partially completed information, programs, inventions, software (including source code), firmware, designs, documentation or data (the “Documents”) developed, created or invented under this Agreement shall be delivered to the County when this Agreement is terminated or completed.

9) NOTICE

Any notice provided or permitted to be given under this Agreement (“Notice”) must be in writing and may be served by (a) depositing same in the United States mail, certified and addressed to the Party to be notified; (b) delivering the same in person to such Party; or (c) sending same by electronic mail (“Email”). Notice given by mail shall be effective upon deposit in the United States mail and Notice delivered in person or sent by Email shall be effective upon receipt. The addresses for Notice are as follows:

COUNTY:

Harris County Engineering Department
1111 Fannin Street, 11th Floor
Houston, Texas 77002
Attention: County Engineer

DISTRICT:

Harris-Waller County Municipal Utility District No. 4
c/o Jessica Holoubek
Allen Boone Humphries Robinson LLP
3200 Southwest Freeway, Suite 2600
Houston, Texas 77027
Email: jholoubek@abhr.com

The Parties may designate another address for all purposes of this Agreement by giving to the other Party not less than fifteen (15) days' advance written notice of such change of address.

All other communications, except for Notices required under this Agreement, may be sent by electronic means or in the same manner as Notices described herein.

10) COMPLIANCE AND STANDARDS

- A) District represents and warrants that it is capable and willing to provide the Maintenance called for in the Agreement, and agrees to render the Maintenance in accordance with the generally accepted standards applicable to the Maintenance. District shall use that degree of care and skill commensurate with the profession to comply with all applicable federal, state, and local laws, ordinances, rules, and regulations relating to the Maintenance and District's performance to be rendered hereunder. District represents that District and its personnel are fully qualified to perform the Maintenance and provide the deliverables described in this Agreement.
- B) District agrees to keep confidential the contents of all its discussions with County officials. District agrees to keep confidential the contents of all County records and all other information obtained during District's performance of Maintenance under this Agreement. District shall not release any confidential information unless the County, in writing, authorizes District to release specific information to any third parties.
- C) District shall not access any information it is not authorized to receive, nor shall District copy, recreate, or use any proprietary information or Documents obtained in connection with this Agreement other than for the performance of this Agreement.
- D) District warrants and represents that it is not in breach of any other contract, obligation or covenant that would affect District's ability to perform hereunder and, as a result of entering into this Agreement, will not breach any such contract, obligation, or covenant.
- E) Conflict of Interest: District warrants and represents to the County that it does not have nor shall it knowingly acquire any interest that would conflict in any manner with the performance of its obligations under this Agreement. Furthermore, District warrants that no company or person, other than a bona fide employee, has been employed to solicit or secure this Agreement with County, and that District has not paid or agreed to pay any company or person, other than a bona fide employee, any fee, commission, percentage, brokerage fee, gift, or any other consideration, contingent upon or resulting from the award or making of this Agreement. For breach or violation of this provision, the County shall have the right to terminate the Agreement without liability.

- F) No Federal Exclusion: District warrants and represents that it is not debarred, suspended, or otherwise excluded from or ineligible for participation in any Federal programs, including but not limited to the following: Department of Health and Human Services (DHHS), Office of Inspector General (OIG) - List of Excluded Individuals & Entities (LEIE); U.S. General Services Administration (GSA) – Excluded Parties List System (EPLS); All States (50) Health & Human Services Commission Medicaid OIG Sanction List; Government Terrorist Watch List (OFAC / Patriot Act); Department of Commerce, Bureau of Industry and Security, Denied Persons List; and Department of Homeland Security, Immigration and Customs Enforcement (ICE) Most Wanted. District must immediately notify the County of any such exclusion or suspension. District warrants and represents that it is in good standing with all State and Federal agencies that have a contracting or regulatory relationship with the County. District warrants and represents that no person who has an ownership or controlling interest in District’s business or who is an agent or managing employee of District has been convicted of a criminal offense related to involvement in any federal program.

- G) County and its designee shall have the right to conduct examinations, studies and audits of the services, payments, and efficiencies provided under this Agreement and County may make such examinations, studies, and audits at any time whether before or after payment. District shall cooperate with such examinations, studies, and audits and provide County with such records, data, documents, including all of District’s backup and support data for billings, and District shall provide access to such records, data, documents and personnel as are requested by County or the County Auditor. This section shall survive termination of this Agreement.

- H) Whistleblower Protection Act: District understands and agrees that this Agreement and employees working on this Agreement will be subject to the whistleblower rights and remedies in the pilot program on contractor employee whistleblower protections established at 41 U.S.C. 4712 by section 828 of the National Defense Authorization Act for Fiscal Year 2013 (Pub. L. 112-239) and FAR 3.908. District shall inform its employees in writing, in the predominant language of the workforce, of employee whistleblower rights and protections under 41 U.S.C. 4712, as described in section 3.908 of the Federal Acquisition Regulation. District shall insert the substance of this clause; paragraph M (“Whistleblower Protection Act”), in all subcontracts providing services under this Agreement.

11) APPLICABLE LAW AND VENUE

- A) The Agreement is subject to the state and federal laws, orders, rules, and regulations relating to the Agreement and funded by state or federal funds or of applicable conditions of participation in Medicaid or Medicare program(s).

- B) This Agreement is governed by the laws of the State of Texas.

- C) The forum for any action under or related to the Agreement is exclusively in a state or federal court of competent jurisdiction in Texas.

- D) The exclusive venue for any action under or related to the Agreement is in a state or federal court of competent jurisdiction in Houston, Harris County, Texas.

12) PROHIBITION ON LIENS

In accordance with Texas Property Code §43.002, the District, or its contractors or agents, will not create or place, or permit to be created or placed, a lien or any other encumbrance on County property. If any such lien or encumbrance is placed on County property, the District shall pursue any lawful effort, including but not limited to seeking relief in a court of competent jurisdiction, to remove the lien or encumbrance from the property.

13) INSURANCE

- A) The District shall acquire and maintain liability insurance with a responsible insurance company or companies, insuring against liability for bodily or personal injury or death or damage to property.
- B) Every such policy of insurance shall provide coverage limits in amounts at least as great as the maximum liability authorized to be imposed against a similar contractor for governmental acts by the Texas Tort Claims Act, Chapter 101, Texas Civil Practices and Remedies Code, as amended and then in effect.
- C) The District shall keep insured the Non-Standard Elements with a responsible insurance company or companies against risks, accidents, or casualties against which and to the extent insurance is usually carried by a similar contractor; provided, however, that at any time while any contractor engaged in construction work shall be fully responsible for the construction work, the District shall not be required to carry insurance on that construction work. In such instances, the District shall require any contractor engaged in construction work to procure, carry and maintain the insurance coverage set forth in this Section.

14) INDEMNIFICATION

TO THE MAXIMUM EXTENT ALLOWED BY LAW, DISTRICT SHALL INDEMNIFY, DEFEND, AND HOLD HARMLESS THE COUNTY FROM AND AGAINST ALL CLAIMS AND LIABILITY DUE TO THE ACTIVITIES OF DISTRICT, OR ANOTHER ENTITY OVER WHICH DISTRICT EXERCISES CONTROL, PERFORMED UNDER THIS AGREEMENT AND WHICH RESULT FROM ANY NEGLIGENT ACT, ERROR, OR OMISSION; INTENTIONAL TORT; INTELLECTUAL PROPERTY INFRINGEMENT; OR FAILURE TO PAY A SUBCONTRACTOR OR SUPPLIER; COMMITTED BY DISTRICT OR ANOTHER ENTITY OVER WHICH DISTRICT EXERCISES CONTROL.

TO THE MAXIMUM EXTENT ALLOWED BY LAW, DISTRICT SHALL ALSO INDEMNIFY, DEFEND, AND HOLD HARMLESS THE COUNTY FROM AND AGAINST ANY AND ALL EXPENSES, INCLUDING REASONABLE ATTORNEY'S FEES WHICH MIGHT BE INCURRED BY THE COUNTY, IN LITIGATION OR OTHERWISE RESISTING SAID CLAIMS OR LIABILITIES WHICH MIGHT BE IMPOSED ON THE COUNTY AS THE RESULT OF SUCH ACTIVITIES BY DISTRICT OR ANOTHER ENTITY OVER WHICH DISTRICT EXERCISES CONTROL.

TO THE MAXIMUM EXTENT ALLOWED BY LAW, DISTRICT SHALL INDEMNIFY, DEFEND, AND HOLD THE COUNTY HARMLESS FROM ANY AND ALL LIABILITY, EXPENSE, JUDGMENT, SUIT, CAUSE OF ACTION, OR DEMAND FOR PERSONAL INJURY, DEATH, OR DIRECT DAMAGE TO TANGIBLE PROPERTY WHICH MAY ACCRUE AGAINST THE COUNTY TO THE EXTENT IT IS CAUSED BY THE

NEGLIGENCE OF DISTRICT OR ANOTHER ENTITY OVER WHICH DISTRICT EXERCISES CONTROL, WHILE PERFORMING SERVICES UNDER THIS AGREEMENT. COUNTY WILL GIVE DISTRICT PROMPT, WRITTEN NOTICE OF ANY SUCH CLAIM OR SUIT. COUNTY SHALL COOPERATE WITH DISTRICT IN ITS DEFENSE OR SETTLEMENT OF SUCH CLAIM OR SUIT.

IF A RESTRAINING ORDER OR TEMPORARY INJUNCTION IS GRANTED DUE TO ANY ACT, ERROR, OR OMISSION COMMITTED BY DISTRICT OR ANOTHER ENTITY OVER WHICH DISTRICT EXERCISES CONTROL, DISTRICT SHALL MAKE EVERY EFFORT, INCLUDING BUT NOT LIMITED TO SECURING A SATISFACTORY BOND, TO OBTAIN THE SUSPENSION OF ANY SUCH RESTRAINING ORDER OR TEMPORARY INJUNCTION.

COUNTY RESERVES THE RIGHT, AT ITS OWN EXPENSE, TO BE INDEPENDENTLY REPRESENTED BY COUNSEL OF ITS OWN CHOICE IN CONNECTION WITH ANY SUCH SUIT OR PROCEEDING.

15) NO FEDERAL EXCLUSION

- A) District warrants that District is not an “Ineligible Person.” An “Ineligible Person” is an individual or entity who:
 - i) is currently excluded, debarred, suspended, or otherwise ineligible to participate in any federal and/or state grant, health care program, or in federal and/or state procurement or non-procurement programs. This includes but is not limited to persons who are on the List of Excluded Individuals or Entities of the Inspector General, List of Parties excluded from Federal Programs by the General Services Administration or the Medicaid Sanction List; or,
 - ii) has been convicted of a criminal offense related to the provision of health care items or services [within the rules and regulations of 42 USC §1320a-7(a)], but has not yet been excluded, debarred, suspended, or otherwise declared ineligible.
- B) District agrees to report immediately to the County if District becomes an “Ineligible Person” during the term of this Agreement.

16) OWNERSHIP OF DOCUMENTS; COPYRIGHT

- A) District agrees that for the purposes of assigning copyright ownership, any and all completed or partially completed data, information, reports, programs, inventions, software, firmware, designs, preliminary layouts, record drawings, digital files, photographs, sketches, and all other electronic or hardcopy documents or documentation (the “Documents”) developed pursuant to the Maintenance performed under this Agreement, shall be the sole property of the County.
- B) District represents that it has the right to assign and hereby assigns to the County all rights, title, copyright ownership and interest in any completed or partially completed data (including source codes), information, reports, programs, inventions, software, firmware, designs, preliminary layouts, record drawings, digital files, photographs, sketches, and all other electronic or hardcopy documents or documentation to be developed or has already

been developed, created or invented pursuant to this Agreement or any other agreements that District may currently have or had in the past, with the County.

- C) Within seven (7) days after its development, creation, or invention, District agrees to deliver to the County, copies, in a form acceptable to the County, of any and all such Documents. District may retain one set of reproducible copies of all Documents for the sole use of performing Maintenance for the County. District is expressly prohibited from selling, donating, licensing or otherwise marketing, or divulging to third parties, any Document, or using such Documents in the preparation of other work for any other client, without the express written permission of the County.

17) AUDIT RIGHTS

- A) Audit Rights. The District shall cooperate to the fullest extent with any and all federal, state, local, or County audits related to this Agreement. The District's cooperation shall include, but not be limited to access to all books, records, contracts, spreadsheets, correspondence, and documents, in whatever form, that are applicable to this Agreement and requested by any federal, state, local, or County entity that has rights or jurisdiction over any part of this Agreement or the funds applicable to this Agreement.
- B) Record Retention. The District agrees to retain within the boundaries of Harris County, for six (6) years after the expiration of this Agreement, all books, records, contracts, spreadsheets, correspondence, and documents applicable to this Agreement. The District will retain and make available, and insert the requisite clause in each applicable subcontract requiring its subcontractors to retain and make available, the books, records, contracts, spreadsheets, correspondence, and documents applicable to this Agreement.

18) WAIVER OF BREACH

Waiver by either Party of a breach or violation of any provision of the Agreement is not a waiver of any subsequent breach.

19) SEVERABILITY

If any provision or part of the Agreement or its application to any person, entity, or circumstance is ever held by any court of competent jurisdiction to be invalid for any reason, the remainder of the Agreement and the application of such provision or part of the Agreement to other persons, entities, or circumstances are not affected.

20) SURVIVAL OF TERMS

Any provision of this Agreement that, by its plain meaning, is intended to survive the expiration or earlier termination of this Agreement including, but not limited to the indemnification provision, shall survive such expiration or earlier termination. If an ambiguity exists as to survival, the provision shall be deemed to survive.

21) CONTRACT CONSTRUCTION

- A) This Agreement shall not be construed against or in favor of any Party hereto based upon the fact that the Party did or did not author this Agreement.

- B) The headings in this Agreement are for convenience or reference only and shall not control or affect the meaning or construction of this Agreement.
- C) When terms are used in the singular or plural, the meaning shall apply to both.
- D) When either the male or female gender is used, the meaning shall apply to both.

22) SUCCESSORS AND ASSIGNS

- A) The County and District bind themselves and their successors, executors, administrators, and assigns to the other Party of this Agreement and to the successors, executors, administrators, and assigns of such other Party, in respect to all covenants of this Agreement.
- B) Neither the County nor District shall assign, sublet, or transfer its interest in this Agreement without written consent of the other Party, which will not be unreasonably withheld.

23) NO THIRD-PARTY BENEFICIARIES

- A) The County is not obligated or liable to any party other than District for the performance of this Agreement.
- B) Nothing in the Agreement is intended or shall be deemed or construed to create any additional rights or remedies in any third party.
- C) Nothing contained in the Agreement shall be construed to or operate in any manner whatsoever to increase the rights of any third party, or the duties or responsibilities of County with respect to any third party.

24) ENTIRE AGREEMENT; MODIFICATIONS

- A) This instrument contains the entire Agreement between the Parties relating to the rights herein granted and obligations herein assumed.
- B) Any oral or written representations or modifications concerning this instrument shall not be effective excepting a subsequent written modification signed by both Parties.

25) EXECUTION, MULTIPLE COUNTERPARTS

This Agreement may be executed in several counterparts. Each counterpart is deemed an original. All counterparts together constitute one and the same instrument. Each Party warrants that the undersigned is a duly authorized representative with the power to execute this Agreement.

[EXECUTION PAGE FOLLOWS]

HARRIS COUNTY

By: _____
Lina Hidalgo, County Judge
Date: _____

**HARRIS-WALLER COUNTY MUNICIPAL
UTILITY DISTRICT NO. 4**

By: 
Rhonda Patterson, President
Date: 8/29/2027

APPROVED AS TO FORM:

CHRISTIAN D. MENELEE
County Attorney

ATTEST:

By: 
Secretary

By: Philip Bergins For:
An Le
Assistant County Attorney
C.A.O. File No.: 23GEN2872



A Conceptual Land Use Plan
of
2303.88 Acres
in Waller/ Harris County,
Texas



LOT TABLE			
Product	Developed/Designed	Future	Total
65'x120'	133	-	133
60'x120'	254	-	254
55'x120'	390	-	390
50'x120'	2,649	-	2,649
45'x120'	1,812	-	1,812
40'x120'	1,538	-	1,538
TOTAL LOTS	6,776	-	6,776

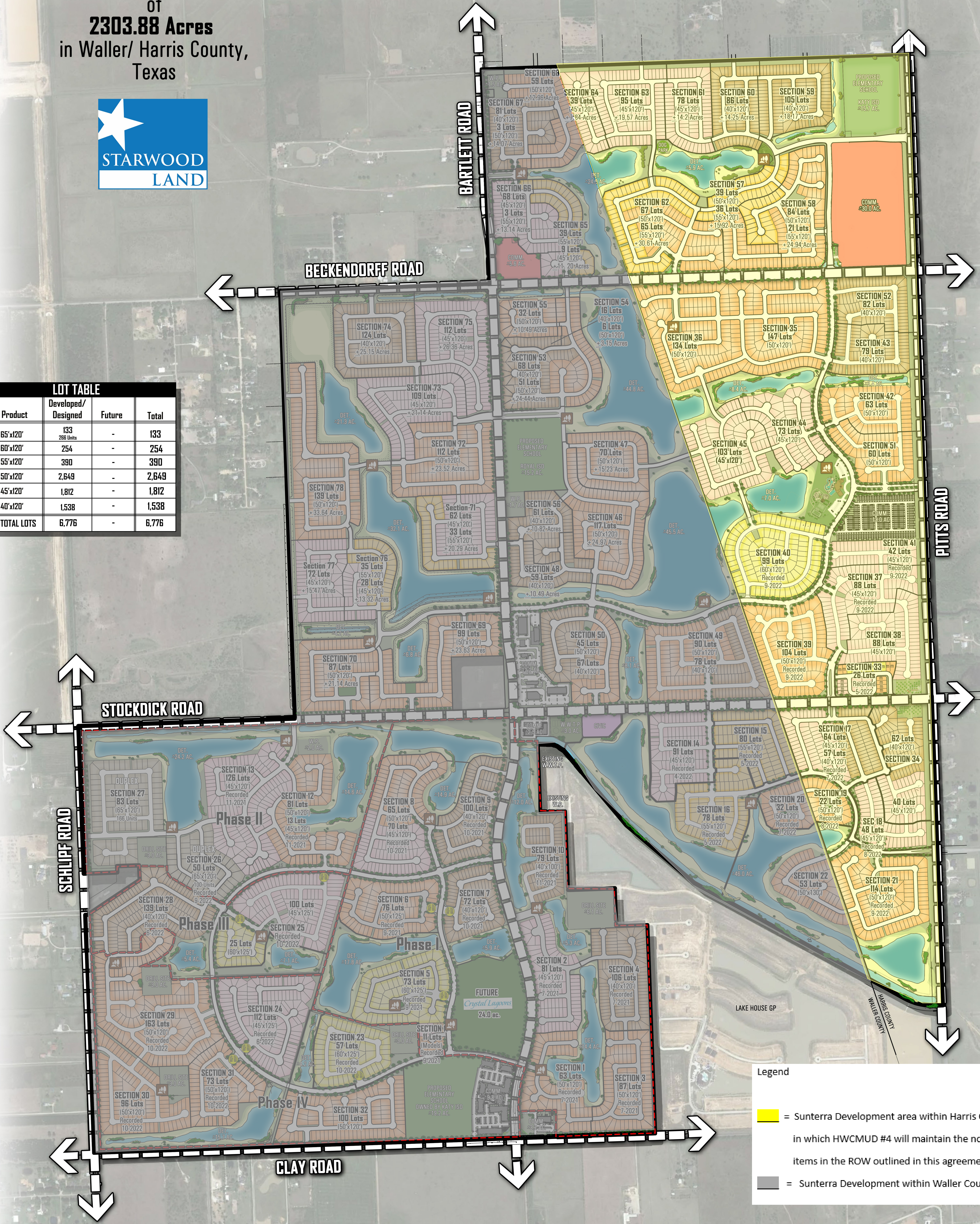

Legend

- = Sunterra Development area within Harris County, in which HWCMUD #4 will maintain the non-standard items in the ROW outlined in this agreement
- = Sunterra Development within Waller County.



THIS PLAN WAS PREPARED USING REASONABLY RELIABLE SOURCES AND IS SUBJECT TO CHANGE PENDING A DETAILED BOUNDARY SURVEY. THIS PLAN HAS NOT BEEN REVIEWED BY ANY GOVERNMENTAL AGENCY. ADDITIONAL STREETS AND/OR DRAINAGE PROVISIONS MAY BE REQUIRED. THIS PLAN IS AN ARTIST'S CONCEPTION AND IS PROVIDED FOR GENERAL INFORMATION PURPOSES ONLY. ALL PLANS FOR FACILITIES OR LAND USES ARE SUBJECT TO CHANGE WITHOUT NOTICE.



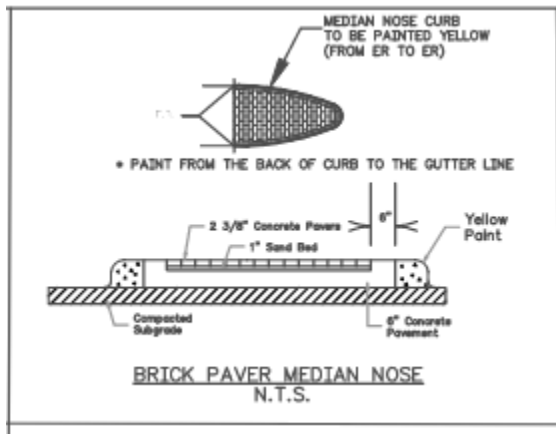
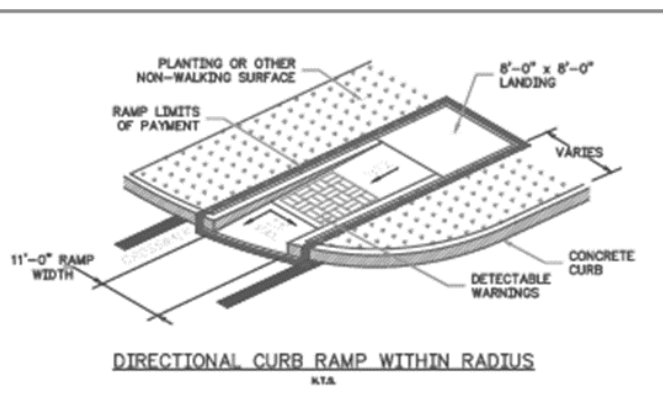
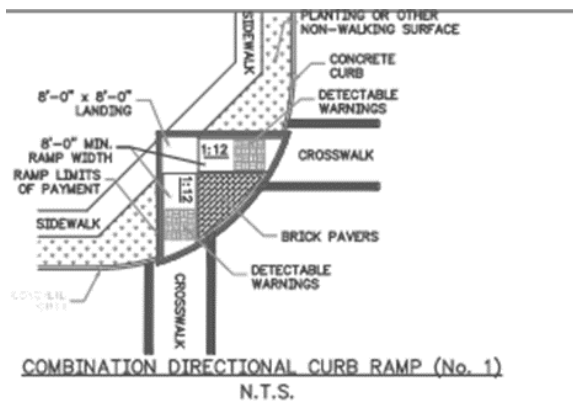

SEE DETAIL "A"

FOR LUMINAIRE
GROUNDING

PE-RELAY
Or
PE-SHORTING CAP

CROSSARM BRACKET

DETAIL "A"

LUM-ARL-DBL-XX Or
LUM-GV-DBL-XX Or
LUM-GV-CG-DBL-XX Or
LUM-MIDTWN-DB-XX Or
LUM-POSTP-DB-XX Or
LUM-TRAD-DBL-XX Or
LUM-GV-45,LED,120-DBL-BK
LUM-MIDTWN-45,LED,120-DBL
LUM-MIDTWN-115,LED,120-DBL

ST5-STD-TRAD-17-DBL
Or
ST5-STD-TRAD-23-DBL
Or
STE-STD-TRAD-17-DBL
Or
STE-STD-TRAD-23-DBL

LUM-ARL-XX Or
LUM-GV-XX Or
LUM-GV-CG-XX Or
LUM-MIDTWN-XX Or
LUM-POSTP-XX Or
LUM-TRAD-XX Or
LUM-GV-45,LED,120-BK Or
LUM-MIDTWN-45,LED,120 Or
LUM-MIDTWN-115,LED,120

ST5-STD-TRAD-17-SGL
Or
ST5-STD-TRAD-23-SGL
Or
STE-STD-TRAD-17-SGL
Or
STE-STD-TRAD-23-SGL

14'-0" ON A 17'-6" STANDARD
19'-0" ON A 23' STANDARD

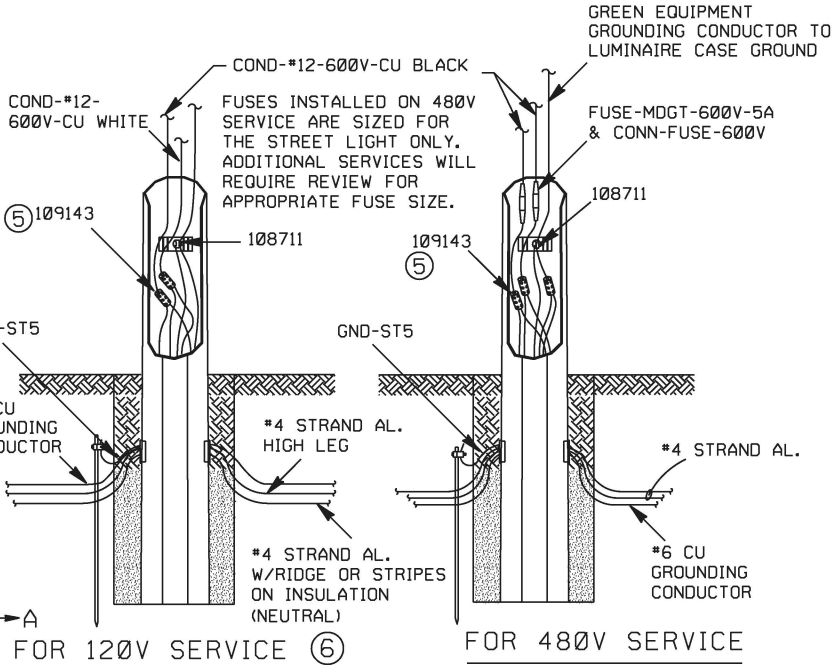

SECTION A-A

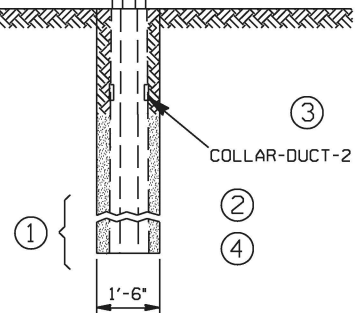
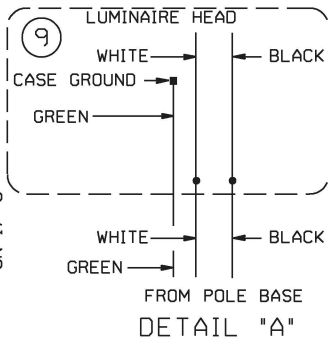

- ① PLACE STANDARD IN HOLE WITH GROUND LEAD INSIDE POLE.
- ② FILL AREA AROUND STANDARD WITH POLYURETHANE POLE FOAM UP TO A POINT 3" BELOW CENTER OF FEED HOLE.
- ③ LEVEL STANDARD AND TAMP BACKFILL.
- ④ FILL REMAINING AREA WITH WELL TAMPED SOIL, FOLLOWED BY BACKFILL.
- ⑤ FOR SPLICE DETAIL SEE UG DISTRIBUTION STANDARDS, SUBSECTION SP4.
- ⑥ SEE UG DISTRIBUTION STANDARD, SECTION ST, SUBSECTION STF, FOR STREET LIGHT CIRCUIT FUSES.
- ⑦ MOUNTING HEIGHT OF TRADITIONAIRE LUMINAIRE ON CROSSARM BRACKET IS 15' ON 17'-6" STANDARD AND 20' ON A 23' STANDARD.
- ⑧ NEUTRAL WIRE TO BE #4 STRAND AL. WITH ONE RIDGE OR STRIPES IN INSULATION ON A 120V CIRCUIT. WITH EXCEPTION OF #6 BARE STRAND CU. ALL WIRES TO HAVE SMOOTH INSULATION FOR IDENTIFICATION OF A 480V CIRCUIT.
- ⑨ FOR ALL LUMINAIRES, A GREEN WIRE SHALL BE INSTALLED FROM THE POLE GROUND TO THE LUMINAIRE CASE GROUND. THE #6 GROUNDING CONDUCTOR AND THE GREEN WIRE MUST BE TIED TOGETHER.

DISTRIBUTION STANDARD
ST5XX/STEXX

DECORATIVE STREET LIGHT
EMBEDDED STANDARDS
(TRADITIONAIRE TYPE)

CenterPoint Energy
HOUSTON, TEXAS

NO.	DATE	REVISION	BY	CH	APP.
8	12-16-2021	REVISED SHEETS 7-22	SCM	JCD	MC
7	03-08-2021	CHANGED BOND WIRE TO GROUNDING CONDUCTOR	KBE	JCD	MC

DRAWN	10-05-04	P.G. WILLIAMS	SECTION	ST	SUB-SECTION	ST5
CHECKED	10-05-04	JAMES C. DAVIS	SHEET	4	OF	22 SHEETS
APPROVED	10-08-04	LEO H. HAAS	DRAWING NUMBER	405	371	18

ORDER OF COMMISSIONERS COURT

The Commissioners Court of Harris County, Texas, met in regular session at its regular term at the Harris County Administration Building in the City of Houston, Texas, on _____, with all members present except _____.

A quorum was present. Among other business, the following was transacted.

ORDER AUTHORIZING AN INTERLOCAL AGREEMENT BETWEEN HARRIS COUNTY AND HARRIS-WALLER COUNTY MUNICIPAL UTILITY DISTRICT NO. 4 TO CONSTRUCT NON-STANDARD ELEMENTS SUCH AS BRICK PAVERS, UPGRADED SIGNS AND SIGNALS, AND UPGRADED CROSSWALKS AND INTERSECTIONS, AND RELATED APPURTENANCES TO BE CONSTRUCTED BY HARRIS-WALLER COUNTY MUNICIPAL UTILITY DISTRICT NO. 4 WITHIN THE EXISTING RIGHT-OF-WAY IN THE SUNTERRA SUBDIVISION LOCATED IN HARRIS COUNTY PRECINCT 4

Commissioner _____ introduced an order and moved that Commissioners Court adopt the order. Commissioner _____ seconded the motion for adoption of the order. The motion, carrying with it the adoption of the order prevailed by the following vote:

	Yes	No	Abstain
Judge Lina Hidalgo	<input type="checkbox"/>	<input type="checkbox"/>	<input type="checkbox"/>
Comm. Rodney Ellis	<input type="checkbox"/>	<input type="checkbox"/>	<input type="checkbox"/>
Comm. Adrian Garcia	<input type="checkbox"/>	<input type="checkbox"/>	<input type="checkbox"/>
Comm. Tom S. Ramsey, P.E.	<input type="checkbox"/>	<input type="checkbox"/>	<input type="checkbox"/>
Comm. Lesley Briones	<input type="checkbox"/>	<input type="checkbox"/>	<input type="checkbox"/>

The County Judge thereupon announced that the motion had duly and lawfully carried and that the order had been duly and lawfully adopted. The order adopted follows:

IT IS ORDERED that:

1. The Harris County Judge is authorized to execute on behalf of Harris County the attached Interlocal Agreement between Harris County and Harris-Waller County Municipal Utility District No. 4 to construct non-standard elements such as brick pavers, upgraded signs and signals, and upgraded crosswalks and intersections, and related appurtenances to be constructed by Harris-Waller County Municipal Utility District No. 4 within the existing right-of-way in the Sunterra Subdivision, located in Harris County Precinct 4.
2. All Harris County officials and employees are authorized to do any and all things necessary or convenient to accomplish the purposes of this order.